



SatLOCK.frame

Safety Level #1

Safety Level #1 *PLUS*

 | Frame height: 2470mm, suitable for internal heights from 2.60m to 2.75m
 | Frame depth: 54mm

 | approx. 70kg per door

 | In operation: -40°C to +80°C

 | In operation max. 50W | in standby approx. 1W | internal backup

 | Thrust force: Up to 500 N

 | Locking bolts SL#1: 3 per door, fixed, 80mm length, 30mm diameter
 4 right door, movable, 100mm length, 30mm diameter
 | Locking bolts SL#1 *PLUS*: 3 per door, fixed, 80mm length, 30mm diameter
 4 both doors, movable, 100mm length, 30mm diameter

Discover the ultimate security solution for the transportation of high-value goods: the SatLOCK High-Value frame not only provides reliable locking for the doors of your trailer or semi-trailer, but also enables convenient remote control. Specially developed for use in the transportation of pharmaceutical or tobacco goods, this solution meets the highest safety requirements, including TAPA-TSR-1 and BAT-V1 certifications.

Our Safety Level #1 version guarantees a high level of security with four movable locking bolts in the right door, that make unauthorized access to the load compartment virtually impossible. Looking for event more safety you can upgrade the frame with another four locking bolts on the left door, achieving the Safety Level #1 *PLUS*. In addition to advanced locking and remote monitoring, the SatLOCK High-Value frame offers additional protection with a robust, mechanical frame design that effectively prevents break-ins.

The integration of sensors from the SatSENS family ensures comprehensive monitoring of the interior and surroundings. Rely on our innovative solution to meet the requirements of your customers and insurance companies in terms of theft protection while optimizing the transport of your high-value goods.



Frame construction with locking bolts



Secure unlocking by code or remotely



Loop cable inside the frame



SatMOS® location



Plug'n'Safe
Solution



PIN Code and
Remote



Security
by loop cable



Location by
SatMOS®



Safety Level #1

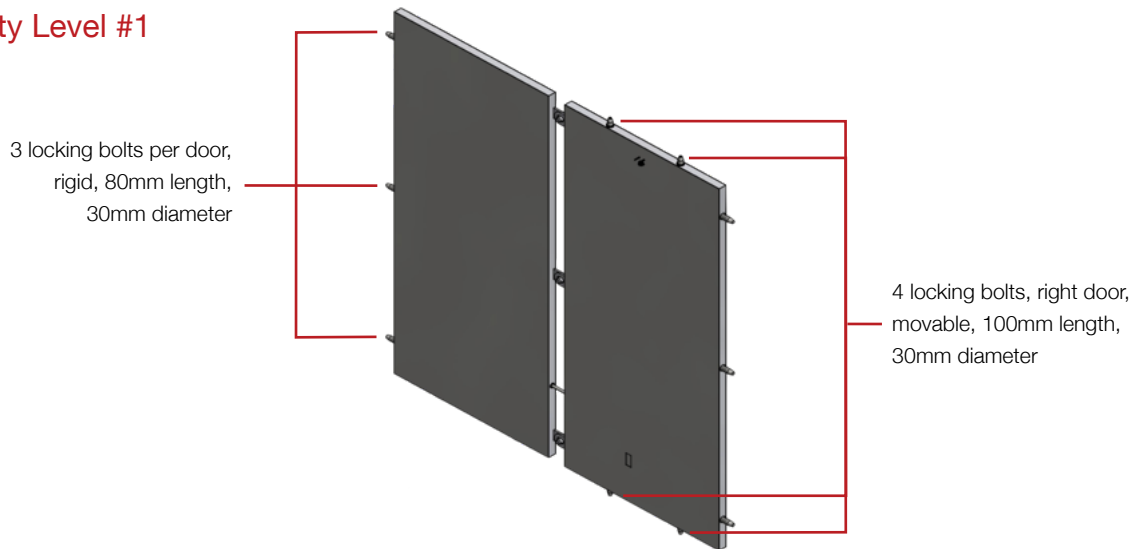

Safety Level #1 PLUS

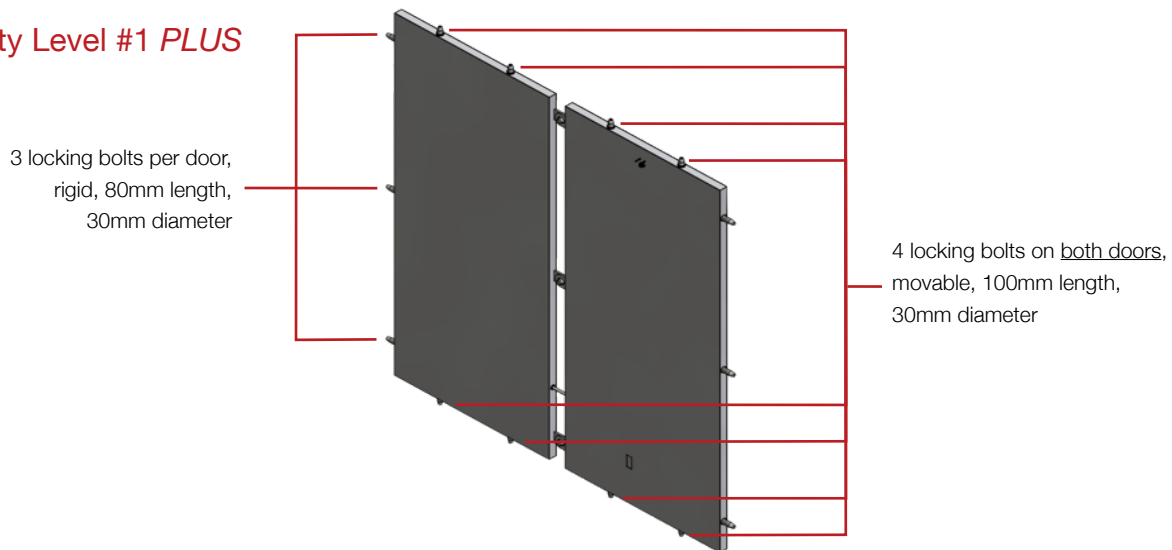

Advantages

- Plug'n'Safe solution - all peripherals pre-installed for quick and easy installation
- Special mechanical frame construction for optimum burglary protection
- Certified solution, compatible with TAPA TSR-1, BAT-V1 etc.
- Adjustable push force, push length and position for optimal installation and application compatibility
- Loop cable inside the frame to detect attempted break-ins through the door
- Mechanical locking of the frame on the driver's side with locking blockade of the right-hand door if the left-hand door is not properly locked
- Unlocking by an automatically changing code via keypad or remotely via remote communication
- Special emergency opening allows unlocking by programmable control
- Partially internal switching and procedure logic enables autonomous reaction to sensors